

MILTON

RESIDENTIAL DRIVEWAY R/E PERMIT

I, _____
 Name of Applicant

of _____
 Email Address

_____ Phone

request permission to construct a residential driveway at

_____ Address or Location of New Driveway

By signing this request the applicant, successors, and assigns agree to construct or have constructed the driveway as described below. Said parties also agree to be responsible for the maintenance of the driveway pipe, safety end sections, and slopes.

Signature: _____

Date: _____

SPECIAL REQUIREMENTS

1. Extend pipe as necessary to obtain a 4:1 or flatter slope
2. The pipe shall be GDOT standard 1030D with a minimum of 18"
3. Existing surface flow to remain. Water shall not be diverted toward Milton right-of-way
4. Safety End Sections required as a minimum
5. No brick or other hazardous mailbox supports allowed on r/w
6. All disturbed r/w to be grassed
7. Driveway segment located in the r/w shall be paved with 6" 3000 PSI concrete or 6" GAB + 3-1/2" asphalt

NOTE:
 Email pwpermits@miltonga.gov for final inspection.

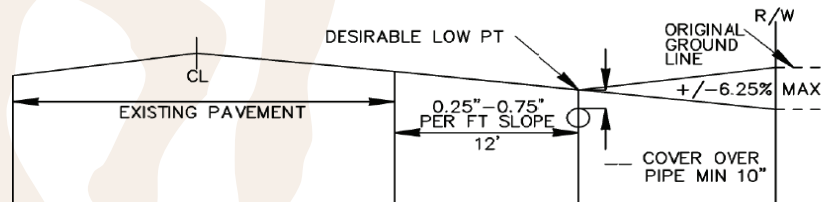
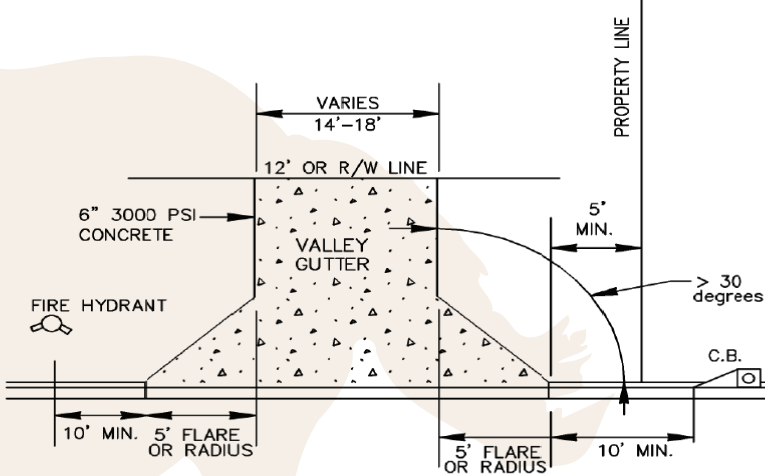
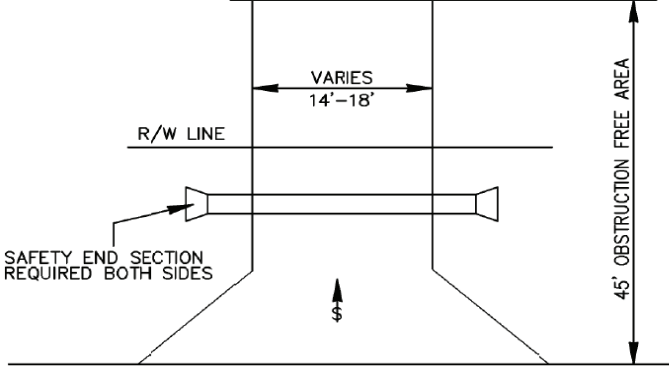

PUBLIC WORKS USE ONLY

Permit Number: _____

Authorized By: _____

Comments: _____

